

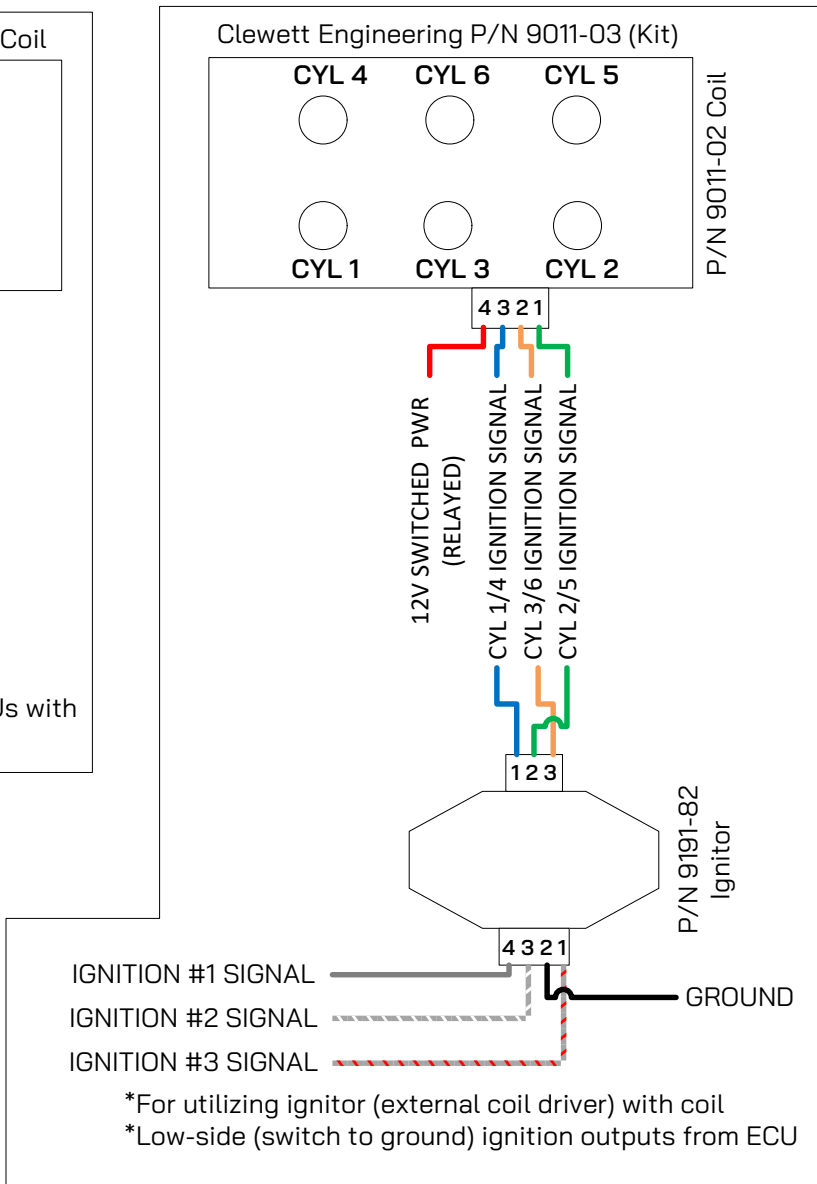

BOSCH 3X2 IGNITION COIL

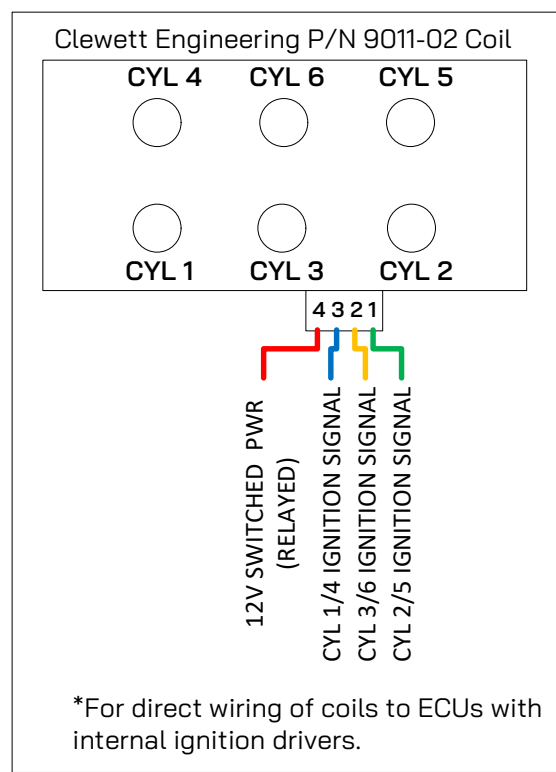

Bosch 3x2 Coil (Clewett Engineering 9011-02)

Volts		Charge (Dwell) Time in milliseconds (ms)				
		0.0	1000	2000	3000	4000
	16.0	2.30	2.30	2.30	2.30	2.30
	14.0	2.70	2.70	2.70	2.70	2.50
	12.0	3.30	3.30	3.30	3.30	2.50
	10.0	4.20	4.20	4.20	3.30	2.50
	8.0	6.00	6.00	5.00	3.30	2.50
	RPM		1000	2000	3000	4000